



SERIES IEFB | INSERTION THERMAL ENERGY METER



IEFB-X-X-TXX

IEFB-X-X-TXX
Shown with A-IEFB-VLV-BR
accessory valve

-LCD option

A-IEFB-THW-XX

Hot-tap thermowells for model
IEFB-X-X-RXX (2), shown with
A-IEFB-VLV-BR-1
accessory valve

FEATURES/BENEFITS

- Flexible, field configurable setup displays (-LCD integral option or remote accessory A-IEF-DSP) accommodate a variety of application configurations. Application information is display selectable and includes pipe size, pipe material, liquid type, analog output, pulse/frequency output, alarm outputs, communication, outputs, damping, and calibration factor
- High performance accuracy is maintained through changes in temperature, density and/or viscosity
- The Setup Wizard and installation tool are simple to use, providing quick and precise installation
- Accessory setup kit A-IEF-KIT comes with a thickness gage and measuring tape to ensure exact installation depth
- The meter has no moving parts and electrodes that discourage fouling, which gives the meter a long lifecycle and minimizes the need for maintenance
- Hot-tap isolation valve accessories allow for easy installation and removal in operational systems without system downtime

APPLICATIONS

- Monitoring chiller cooling output performance
- Industrial boiler heating performance
- Energy efficiency monitoring
- Optimization of heat energy performance
- Commercial and residential heat energy consumption and metering
- District heating and cooling monitoring
- Energy cost allocation monitoring

DESCRIPTION

The **Series IEFB** is a field-adjustable insertion thermal energy meter that uses electromagnetic technology to accurately and reliably measure fluid velocity and energy consumption. The flowmeter is simple to install and is adjustable to fit pipe sizes from 4 to 10" (100 to 900 mm). The IEFB incorporates a temperature meter and a calculator into a single unit. The LCD display provides clear readings of the meter's values, including temperature and energy consumption, making it ideal for installation on chillers, boilers, and other heating and cooling applications. In addition, it offers several output options, including selectable BACnet MS/TP or Modbus® RTU communications protocol over 2-wire RS-485 and standard analog, frequency, and alarm outputs. Furthermore, the superior performance of the IEFB keeps annual operating costs at a minimum, thanks to its combination of high measuring accuracy and long lifetime.

SPECIFICATIONS

Service	Compatible clean or dirty non coating, conductive liquids.
Range	0 to 20 ft/s (0 to 6 m/s).*
Wetted Materials	Body shaft/fitting: 316 SS; Electrodes: 316 SS; Electrode cap: Polymer/polystyrene; O-ring: Silicone. Thermowells: 316 SS.
BTU Accuracy per EN1434/ASTM E3137/ CSA C900.1-13	High accuracy units: Class 2 for 2 to 20 ft/s (0.6 to 6 m/s)**; Standard accuracy units: Class 3 for 6.5 to 20 ft/s (2 to 6 m/s)**.
Flow Sensor Accuracy	High accuracy units: $\pm 0.5\%$ of reading at calibrated velocity, $\pm 1\%$ of reading from 2 to 20 ft/s (0.6 to 6 m/s) ± 0.02 ft/s (± 0.006 m/s) at < 2 ft/s (0.6 m/s); Standard accuracy units: $\pm 1\%$ FS.
Temperature Accuracy	Class B $\pm(0.30 + 0.005 \cdot t)$ °C per EN60751.
Differential Temperature Accuracy	$E_t = \pm(0.5 + 3 \cdot \Delta\theta_{\min}/\Delta\theta)$ % per EN1434.
Calculator Accuracy	$E_c = \pm(0.5 + \Delta\theta_{\min}/\Delta\theta)$ % per EN1434.
RTD Accuracy	Accuracy class: Class B $\pm(0.30 + 0.005 \cdot t)$ °C per EN60751 Accuracy: $E_t = \pm(0.5 + 3 \cdot \Delta\theta_{\min}/\Delta\theta)$ % per EN1434.
Temperature Compensation	140 to 220°F (60 to 104.4°C) $< 2\%$ error over ± 30 °F (-1.1 °C) change, 40 to 70°F (4.4 to 21.1°C) $< 2\%$ error over ± 10 °F (-12.2 °C) change.
Temperature Limits	Ambient: -20 to 160°F (-29 to 71°C);** Process: 32 to 250°F (0 to 121°C); Storage: -40 to 185°F (-40 to 85°C).
Process Connection	Flowmeter: 1" NPT or BSPT with accessory full port ball valve options; Thermowell: (2) 1/2" NPT or BSPT thermowell with full port ball valve option.
Pressure Limit	400 psi (27.6 bar) @ 100°F (37.8°C).
Pressure Drop	< 0.1 psi at 12 ft/s in 4" (< 0.01 bar at 3.7 m/s in 100 mm) and larger pipe.
Outputs	(1) Analog: 4-20 mA, 0-5 V, 0-10 V or 2-10 V (display selectable); (1) Pulse/Frequency: 0-15 V peak pulse, 0-500 Hz or scalable pulse output (display selectable); (2) Alarm: Empty pipe detection or minimum/maximum velocity, (display selectable) and reverse flow output indication.
Power Requirements	12-42 VDC, .25 A @ 24 VDC; 12-36 VAC.
Electrical Connection	Removable terminal blocks, (2) model selectable 1/2" female NPT conduit connection, (2) PG 16 gland or (2) PG 16 gland with 10 ft (3 m) 9 conductor 22 AWG plenum rated cables, accessory cable lengths up to 200 ft (61 m) optional.
Display (-LCD option)	2 x 2" (50 x 50 mm) graphic LCD with backlight.
Conductivity	> 20 microsiemens.
Enclosure Material	Powder coated die cast aluminum.
Enclosure Ratings	NEMA 6P (IP68) (Non display models); NEMA 4X (IP66) (-LCD option).
Agency Approvals	BTL.
*For max flowrates > 10 ft/s (3 m/s) order option -CC.	
**Verified at standard temperature 73.4°F (23°C) refer to listed standards for detailed accuracy formulations.	

COMMUNICATIONS (-COM OPTION)

Type	BACnet MS/TP or Modbus® RTU communication protocol (default disabled, display selectable).
Support Baud Rates	9600, 19200, 38400, 57600, 76800, or 115200 bps (display selectable).
Device Load	1/8 unit load.

ADDITIONAL SPECIFICATIONS

Applicable Pipe Material	Most popular plastic and metal pipes; i.e. Carbon steel, SS, copper, UPVC/PVDF, galvanized steel, mild steel, and brass.
Applicable Pipe Size	4-36" (100 to 900 mm), model dependent. See model chart.
Diameter Length Requirements	> 10 upstream, > 5 downstream.
Temperature Resistance	Matched 4 wire platinum RTD's.
Relative Humidity	10 to 90% non-condensing.
Output Impedance	4-20 mA: 536 Ω ; 5V: 500 Ω ; 10V: 1.27k Ω .
**Units with display have a higher minimum ambient temperature range.	

DIMENSIONS

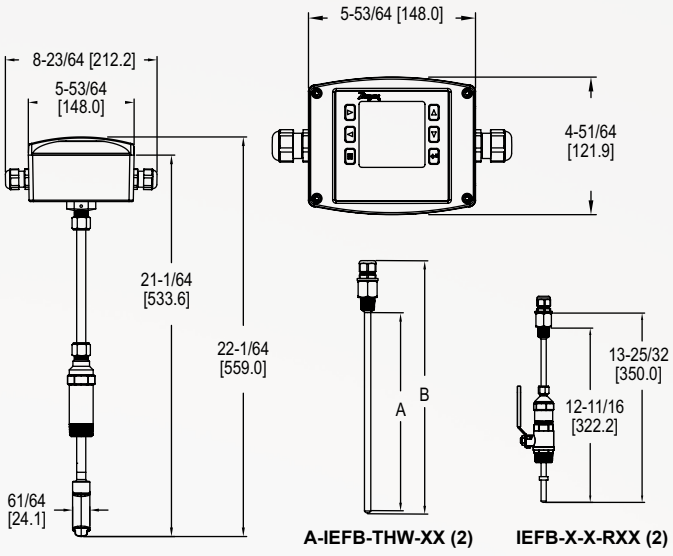

THERMOWELL MODEL CHART		
Model	A	B
A-IEFB-THW-4	4-11/16" (119.0 mm)	5-25/32 (146.8 mm)
A-IEFB-THW-6	6-11/16" (169.8 mm)	7-25/32 (197.6 mm)

WIRING DIAGRAM

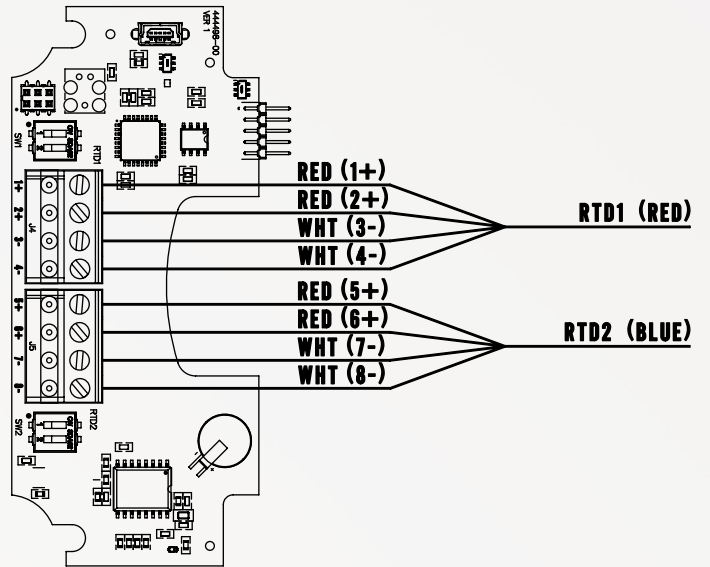

HOW TO ORDER

Use the **bold** characters from the chart below to construct a product code.

<p>SERIES</p> <p>IEFB: Insertion thermal energy meter</p> <p>ACCURACY</p> <p>-L: Standard accuracy <10" (250 mm) pipe; 1% FS -G: Standard accuracy >10" (250 mm) pipe; 1% FS -S: Standard accuracy 4 to 36" (100 to 900 mm) pipe; 1% FS -F: High accuracy 4" (100 mm) pipe; 1% of reading -I: High accuracy 6" (150 mm) pipe; 1% of reading -E: High accuracy 8" (200 mm) pipe; 1% of reading -T: High accuracy 10" (250 mm) pipe; 1% of reading -H: High accuracy 4 to 10" (100 to 250 mm) pipe; 1% of reading</p> <p>PROCESS CONNECTION</p> <p>N: 1" male NPT B: 1" male BSPT</p> <p>ELECTRICAL HOUSING CONNECTOR</p> <p>-CND: 1/2" female NPT -PG: PG 16 gland without cable -10: PG 16 gland with (2) 10' (3 m) plenum rated cables</p>	<p>IEFB -H N -CND -R10 -LCD</p>	<p>SIZE</p> <p>-LCD: Integral LCD -COM: BACnet or Modbus® communication protocol -NIST: NIST traceable calibration certification -FC: Factory calibration certification, ±0.5% of reading at specific point -CC: Custom configuration</p> <p>TEMPERATURE SENSORS</p> <p>-T10: (2) 10' (3 m) PT temperature sensors -T20: (2) 20' (6 m) PT temperature sensors -T50: (2) 50' (15 m) PT temperature sensors -R10: (2) 10' (3 m) PT temperature sensors with hot-tap thermowell sensor assembly -R20: (2) 20' (6 m) PT temperature sensors with hot-tap thermowell sensor assembly -R50: (2) 50' (15 m) PT temperature sensors with hot-tap thermowell sensor assembly</p>
---	---	---

Note: FOR MAXIMUM PERFORMANCE SELECT -LCD OPTION OR SETUP DISPLAY ACCESSORY.

ACCESSORIES

Model	Description
A-IEF-KIT	Setup kit (includes setup display, thickness gage, and measuring tape) and universal power adapter
A-IEF-DSP	Setup display
A-IEF-VLV-BR†	1-1/4" full port isolation valve brass kit**
A-IEF-VLV-SS†	1-1/4" full port isolation valve 316 SS kit
Thermowells	
A-IEFB-THW-4	(2) 1/2" NPT, 4" thermowell for 4 to 7" pipe
A-IEFB-THW-6	(2) 1/2" NPT, 6" thermowell for ≥ 8" pipe
A-IEFB-THW-4-BSPT	(2) 1/2" BSPT, 4" thermowell for 4 to 7" pipe
A-IEFB-THW-6-BSPT	(2) 1/2" BSPT, 6" thermowell for ≥ 8" pipe
Hot-Tap Valves	
A-IEFB-VLV-BR-1†	(2) 1" NPT full port isolation valve brass for temperature sensor with 1" branch outlet and 1" nipple**
A-IEFB-VLV-SS-1†	(2) 1" NPT full port isolation valve 316 SS for temperature sensor with 1" branch outlet and 1" nipple

**Brass fittings and pipe are not to be used with NSF Certified models. Brass valves are non-RoHS compliant.
†BSPT valves also available

Modbus® is a registered trademark of Schneider Automation, Inc.

ORDER ONLINE AT www.dwyerinst.com/Product/Series/IEFB



DWYER INSTRUMENTS, INC.

©Copyright 2020 Dwyer Instruments, Inc.
 Printed in U.S.A.7/20

DS-IEFB Rev. 2

Important Notice: Dwyer Instruments, Inc. reserves the right to make changes to or discontinue any product or service identified in this publication without notice. Dwyer advises its customers to obtain the latest version of the relevant information to verify, before placing any orders, that the information being relied upon is current.